

4

3

2

1

D

D

C

C

B

B

A

A

**REVISIONS**

ZONE	REV.	DESCRIPTION	DATE	APPR.

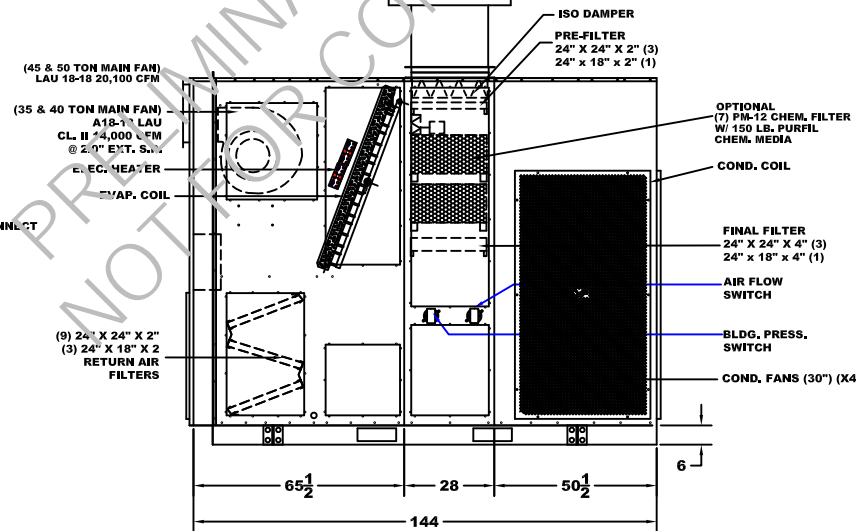
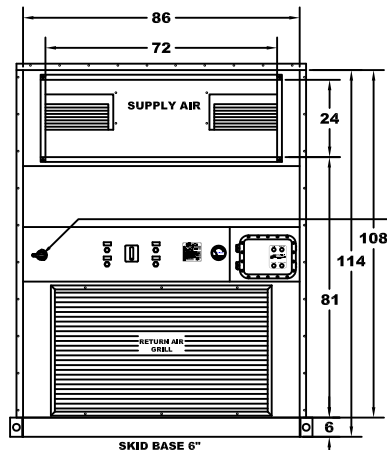
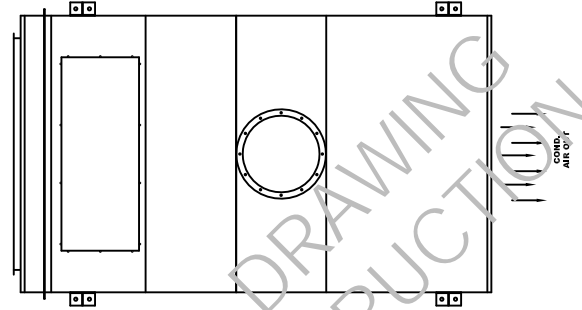
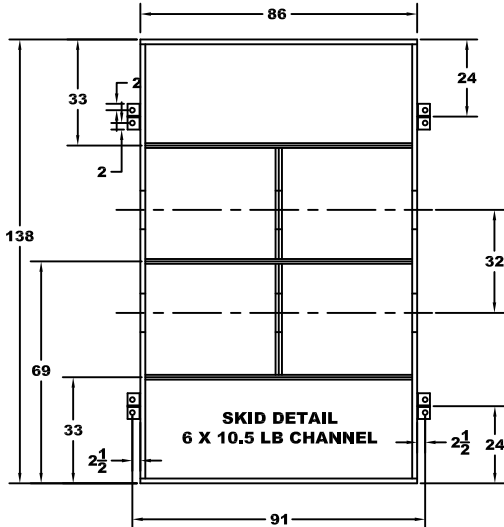

**APPROX. UNIT WEIGHT 6500 LBS**

<b>DRAWING STATUS</b>	
ISSUED FOR APPROVAL	<input type="checkbox"/>
FOR CONSTRUCTION	<input type="checkbox"/>
AS BUILT	<input type="checkbox"/>



**TITLE:**  
**GENERAL ARRANGEMENT**  
**MODEL 16420/16480/16600**

<b>SCALE:</b>	<b>DRAWN BY:</b> DM	<b>P.O.#:</b>
<b>DATE:</b>	<b>CHK'D:</b>	<b>JOB#:</b> 16000
	<b>REV:</b>	<b>DWG#:</b> 16000-01

THIS DOCUMENT CONTAINS CONFIDENTIAL PROPRIETARY INFORMATION AND IS THE PROPERTY OF SPECIFIC SYSTEMS. IT SHALL NOT BE REPRODUCED, USED, TRANSFERRED TO OTHER DOCUMENTS OR DISCLOSED TO ANY UNAUTHORIZED PERSONS WITHOUT THE EXPRESS WRITTEN PERMISSION OF SPECIFIC SYSTEMS. ALL RIGHT OF DESIGN OR INVENTION ARE RESERVED TO SPECIFIC SYSTEMS.

4

3

2

1