

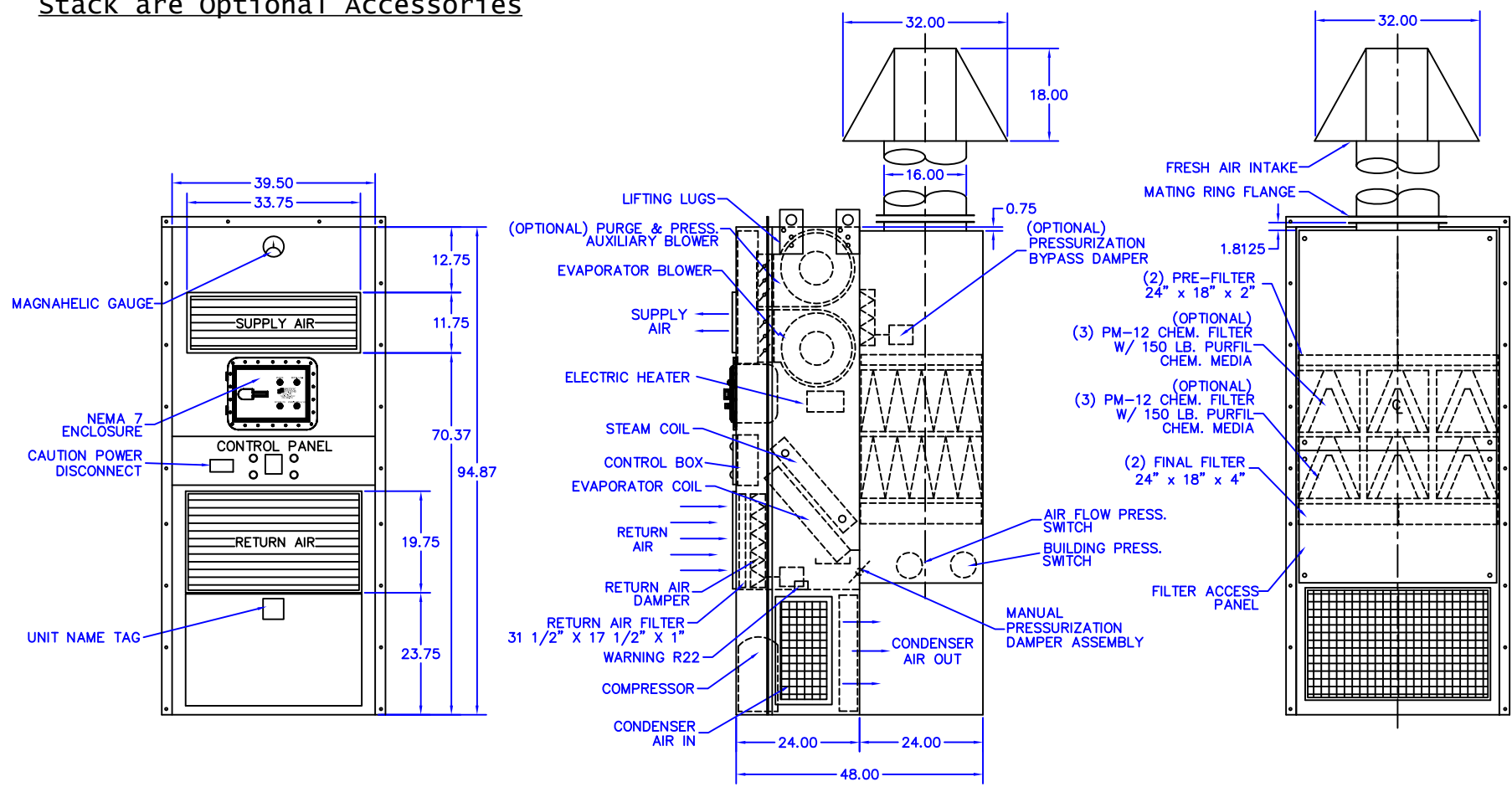

REVISIONS				
ZONE	REV	DESCRIPTION	DATE	APPROVED

Chemical Filter Box,
Auxiliary Blower, and
Stack are Optional Accessories



NOTE: PNEUMATIC TUBING
 GREEN - AIR FLOW SWITCH (HIGH)
 YELLOW - BLDG. PRESS. SWITCH (HIGH)
 BLUE - AIR FLOW / BLDG. PRESS. (LOW)

 SPECIFIC SYSTEMS 7655 E. 41ST, TULSA, OK. 74145 U.S.A. (918) 663-9321	<small>THIS DOCUMENT CONTAINS CONFIDENTIAL PROPRIETARY INFORMATION AND IS THE PROPERTY OF SPECIFIC SYSTEMS. IT SHALL NOT BE REPRODUCED, USED, TRANSFERRED TO OTHER DOCUMENTS OR DISCLOSED TO ANY UNAUTHORIZED PERSONS WITHOUT THE EXPRESS WRITTEN PERMISSION OF SPECIFIC SYSTEMS. ALL RIGHT OF DESIGN OR INVENTION ARE RESERVED TO SPECIFIC SYSTEMS.</small>		
	SIZE:	SCALE:	REV:
	P.O.#:	DRAWN BY:	CHK'D:
	DATE:	JOB#:	DWG#:
TITLE: GENERAL ARRANGEMENT MODEL 600 W/ AUX. FAN & CHEM. FILTER		07/19/07	SALES-94