

REVISIONS				
ZONE	REV	DESCRIPTION	DATE	APPROVED

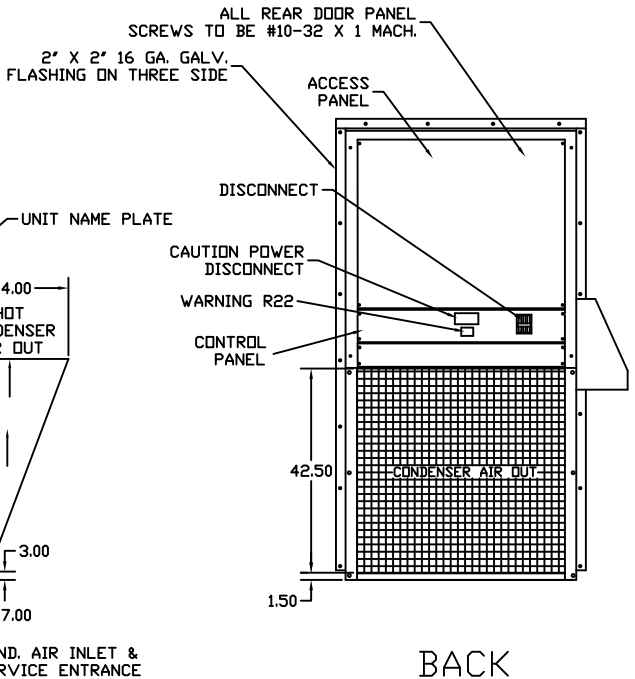
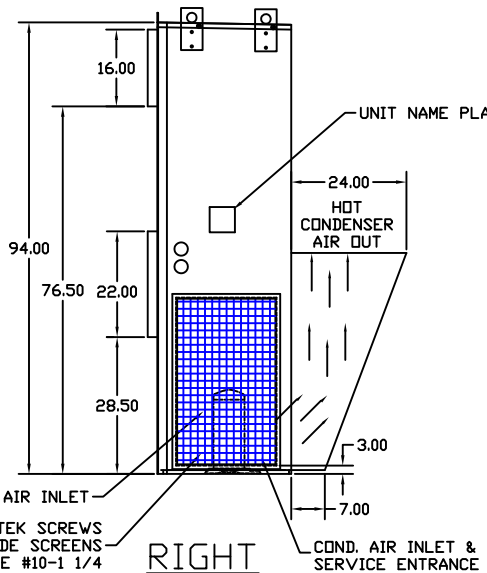
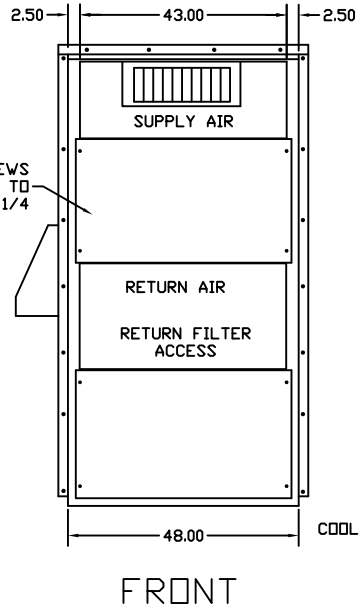
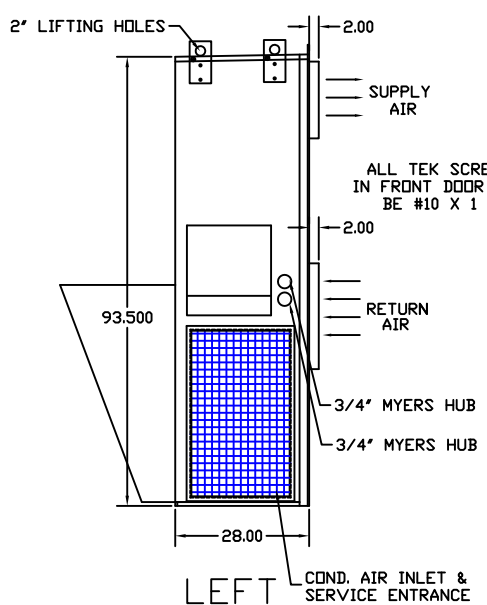

DIMENSIONS MEASURED AT THE TOP ARE 3/16" WIDER

UNIT WEIGHT 1200 LBS.

<p>SPECIFIC SYSTEMS 7655 E. 41ST, TULSA, OK, 74145 U.S.A. (918) 663-9321</p>	<p>THIS DOCUMENT CONTAINS CONFIDENTIAL PROPRIETARY INFORMATION AND IS THE PROPERTY OF SPECIFIC SYSTEMS. IT SHALL NOT BE REPRODUCED, USED, TRANSFERRED TO OTHER DOCUMENTS OR DISCLOSED TO ANY UNAUTHORIZED PERSONS WITHOUT THE EXPRESS WRITTEN PERMISSION OF SPECIFIC SYSTEMS. ALL RIGHT OF DESIGN OR INVENTION ARE RESERVED TO SPECIFIC SYSTEMS.</p>			
	TITLE:	SIZE:	SCALE:	REV:
	GENERAL ARRANGEMENT MODEL APK 90/120 STD. TOP HORIZONTAL DISCHARGE	P.O.#:	DRAWN BY: DM	CHK'D:
		DATE: 05/14/09	JOB#: 726000	DWG#: 726000-01